

Item No.	6e_Attach_A
Date of Meeting	October 23, 2012

## RESOLUTION NO. 3669

### A RESOLUTION

of the Port Commission of the Port of Seattle declaring certain permanent access easements, and the electrical infrastructure improvements located at: 2585 S 194<sup>th</sup> St, SeaTac, WA, on Port property on S 194<sup>th</sup>/196<sup>th</sup> St, SeaTac, WA, within the public right of way on 28<sup>th</sup> Ave S, SeaTac, WA, within the public right of way on International Blvd, SeaTac, WA, and at 3150 S 160<sup>th</sup> St, SeaTac, WA to be surplus and no longer needed for port district purposes and authorizing the Chief Executive Officer to execute all documents necessary for conveyance of the permanent access easements on the real property and title to these electrical infrastructure improvements to the City of Seattle and Puget Sound Energy.

**WHEREAS**, the Rental Car Facility project required the extension, relocation and/or modification of the City of Seattle's ("City") electrical infrastructure; and

**WHEREAS**, the Bus Maintenance Facility project required the extension, relocation and/or modification of Puget Sound Energy's ("PSE") electrical infrastructure; and

**WHEREAS**, on June 30, 2009, the Port of Seattle Commission authorized the Chief Executive Officer to prepare and execute utility agreements in support of the Rental Car Facility project; and

**WHEREAS**, in May 2010, the Port of Seattle entered into a utility agreement with the City regarding the provision of electrical service and the ownership of the electrical infrastructure improvements by the City for the Rental Car Facility project; and

**WHEREAS**, on February 2, 2010, the Port of Seattle Commission authorized the Chief Executive Officer to prepare and execute utility agreements in support of the Bus Maintenance Facility project; and

**WHEREAS**, in April 2011, the Port of Seattle entered into a utility agreement with PSE regarding the provision of electrical service, the ownership of the electrical infrastructure improvements by PSE, and the granting of utility easements on Port property for the Bus Maintenance Facility project; and

**WHEREAS**, the Rental Car Facility project relocated a City electrical ductbank located within public right-of-way on International Blvd, SeaTac, WA, and extended the electrical ductbank and provided supporting infrastructure for a new electrical service located on Port property at 3150 S 160<sup>th</sup> St, SeaTac, WA; and

**WHEREAS**, the Bus Maintenance Facility project relocated a PSE electrical ductbank located within public right of way on 28<sup>th</sup> Ave S, SeaTac, WA, and on Port property on S 194<sup>th</sup>/196<sup>th</sup> St, SeaTac, WA, and extended the electrical ductbank and provided supporting infrastructure for a new electrical service located on Port property at 2585 S 194<sup>th</sup> St, SeaTac, WA; and

**WHEREAS**, pursuant to the terms of the utility agreements, the title to the electrical infrastructure improvements for the Rental Car Facility project is to be transferred to the City; and

**WHEREAS**, pursuant to the terms of the utility agreements, the title to the electrical infrastructure improvements and a permanent easement for access to the electrical infrastructure improvements for the Bus Maintenance Facility project is to be transferred to PSE; and

**WHEREAS**, Chapter 39.33 of the Revised Code of Washington provides that the Port may “sell, transfer, exchange, lease or otherwise dispose of any property ... to the state or any municipality or any political subdivision thereof ... on such terms and conditions as may be mutually agreed upon ...”; and

**WHEREAS**, the electrical infrastructure improvements for the Rental Car Facility and Bus Maintenance Facility projects are located on the real property (“Property”) described on attached Exhibits A and B; and

**WHEREAS**, the electrical infrastructure improvements located on the Property and described in Exhibits A and B are no longer needed by the Port and can be declared surplus; and

**WHEREAS**, the estimated fair market value of the electrical infrastructure improvements for the Rental Car Facility project is \$312,000, and the estimated fair market value of the electrical infrastructure improvements for the Bus Maintenance Facility is \$362,000, for a total of \$674,000 for the electrical infrastructure improvements for both facilities.

**NOW, THEREFORE, BE IT RESOLVED** by the Port Commission of the Port of Seattle that:

Section 1. The electrical infrastructure improvements located on the Property described on Exhibits A and B attached to this Resolution are no longer needed for Port purposes and are declared surplus.

Section 2. Pursuant to Chap. 39.33 RCW, the Chief Executive Officer is authorized to take all steps and execute all documents necessary to convey title to the electrical infrastructure improvements located on the Property to the City and PSE. The electrical infrastructure improvements located on the Property for the Rental Car Facility and Bus Maintenance Facility projects have an estimated fair market value of \$674,000.

Section 3. The Chief Executive Officer is authorized to take all steps and execute all documents necessary to convey permanent access easements described on Exhibit A to the City and to PSE.

**ADOPTED** by the Port Commission of the Port of Seattle at a regular meeting thereof, held this \_\_\_\_\_ day of \_\_\_\_\_, 201\_\_\_\_, and duly authenticated in open session by the signatures of the Commissioners voting in favor thereof and the seal of the Commission.

---

---

---

---

---

Port Commissioners

**CONSOLIDATED RENTAL CAR FACILITY SITE  
SCL DUCTBANK EASEMENT**

A STRIP OF LAND 10 FEET IN WIDTH SITUATED IN THE SOUTHWEST QUARTER OF SECTION 22, TOWNSHIP 23 NORTH, RANGE 4 EAST, W.M., CITY OF SEATAC, COUNTY OF KING, STATE OF WASHINGTON, THE SIDELINES OF SAID STRIP BEING 5 FEET ON EACH SIDE OF THE FOLLOWING DESCRIBED CENTERLINE:

COMMENCING AT THE CORNER COMMON TO SECTIONS 21, 28, 27, AND SAID SECTION 22, THENCE NORTH 89°55'51" EAST, ALONG THE SOUTH LINE OF SAID SECTION 22, ALSO BEING THE CENTERLINE OF SOUTH 160<sup>TH</sup> STREET, A DISTANCE OF 25.36 FEET TO THE CENTERLINE OF PACIFIC HIGHWAY SOUTH, ALSO KNOWN AS INTERNATIONAL BOULEVARD;

THENCE NORTH 18°41'49" EAST, ALONG THE CENTERLINE OF SAID PACIFIC HIGHWAY, A DISTANCE OF 991.38 FEET;

THENCE NORTH 71°18'51" WEST, A DISTANCE OF 62.56 FEET, TO THE WEST RIGHT-OF-WAY MARGIN OF SAID PACIFIC HIGHWAY SOUTH AND THE POINT OF BEGINNING OF SAID DESCRIBED CENTERLINE, ALSO BEING AN INTERSECTION WITH A NON-TANGENT 16.13 FOOT RADIUS CURVE CONCAVE TO THE SOUTHWEST, WHICH ITS CENTER BEARS SOUTH 74°57'48" WEST.

THENCE NORTHWESTERLY ALONG THE ARC OF SAID CURVE, THROUGH A CENTRAL ANGLE OF 29°34'14", A DISTANCE OF 8.32 FEET;

THENCE NORTH 45°40'50" WEST, A DISTANCE OF 167.15 FEET TO THE BEGINNING OF A CURVE CONCAVE TO THE SOUTH HAVING A RADIUS OF 14.69 FEET;

THENCE NORTHWESTERLY ALONG THE ARC OF SAID CURVE THROUGH CENTRAL ANGLE OF 89°13'20", A DISTANCE OF 22.87 FEET;

THENCE SOUTH 44°17'00" WEST, A DISTANCE OF 21.67 FEET TO A POINT HEREON REFERRED TO AS POINT "A", AND ALSO BEING THE TERMINUS OF SAID DESCRIBED CENTERLINE.

THE SIDELINES OF SAID STRIP TO BE LENGTHENED OR SHORTENED TO INTERSECT AT ALL ANGLE POINTS AND TO TERMINATE ON A LINE PERPENDICULAR TO SAID CENTERLINE AT SAID TERMINUS, AND AT SAID POINT "A".

TOGETHER WITH THE FOLLOWING DESCRIBED PORTION:

BEGINNING AT AFORESAID POINT "A", THENCE SOUTH 45°42'02" EAST A DISTANCE OF 52.01 FEET;

THENCE SOUTH 44°21'12" WEST A DISTANCE OF 42.91 FEET;

THENCE NORTH 45°49'31" WEST A DISTANCE OF 60.33 FEET;

THENCE NORTH 44°07'08" EAST A DISTANCE OF 43.04 FEET;

THENCE SOUTH 45°42'00" EAST A DISTANCE OF 8.50 FEET, TO SAID POINT "A" AND THE POINT OF BEGINNING.

ALL CONTAINING 4800 SQUARE FEET OR .11 ACRES, MORE OR LESS.



9/26/12



**PORTION OF  
SECTION 22, TWN. 23 N, RNG. 04 E., W.M.,  
KING COUNTY, WASHINGTON**

CURVE TABLE			
CURVE	LENGTH	RADIUS	DELTA
C1	8.32	16.13	29°34'14"
C2	22.87	14.69	89°13'20"

LINE TABLE		
LINE	LENGTH	BEARING
L1	25.36	N89°55'51"E
L2	991.38	N18°41'09"E
L3	62.56	N71°18'51"W
L4	167.15	N45°40'50"W
L5	21.67	S44°17'00"W
L6	52.01	S45°42'02"E
L7	42.91	S44°21'12"W
L8	60.33	N45°49'31"W
L9	43.04	N44°07'08"E
L10	8.50	S45°42'00"E

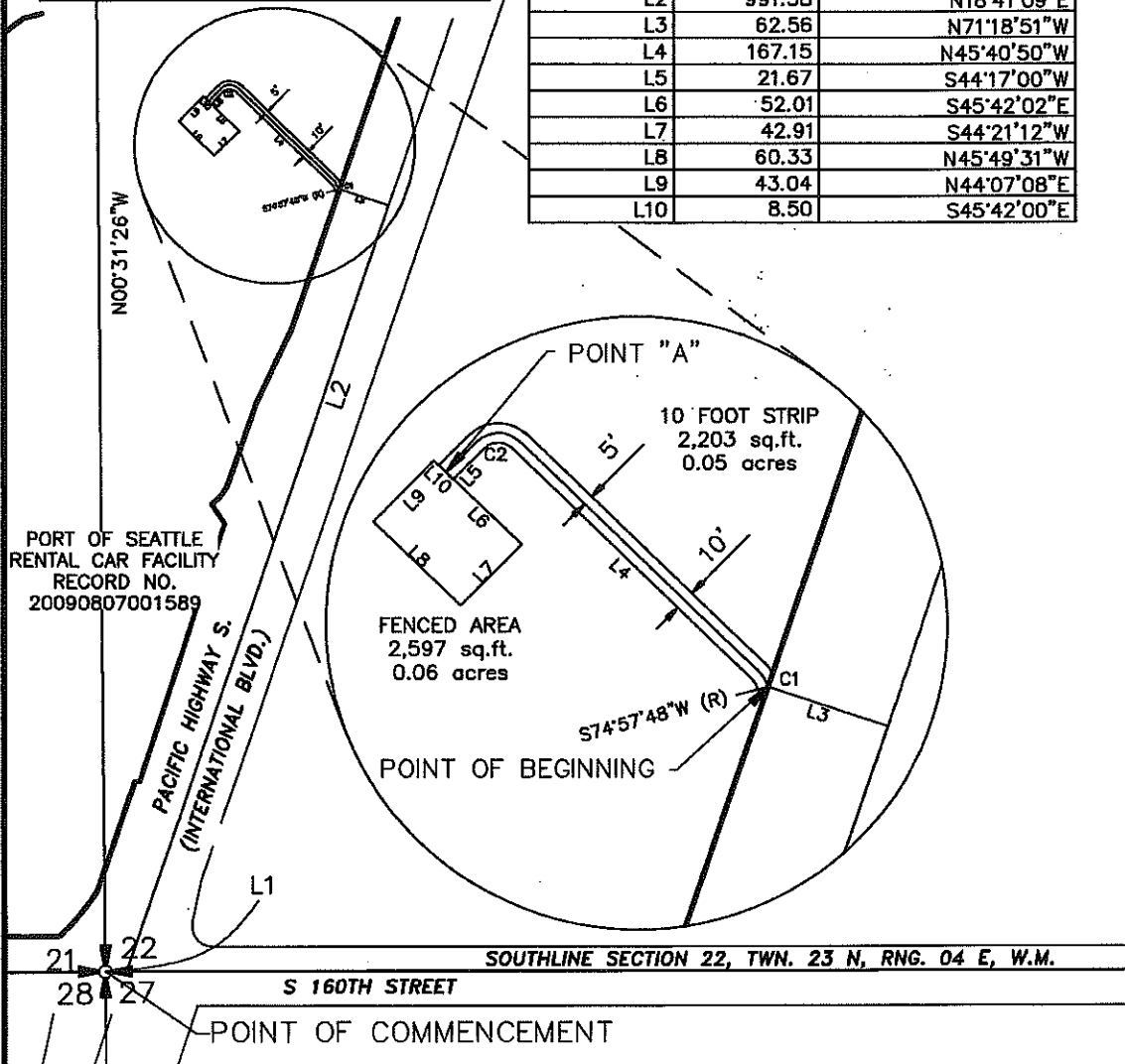

	<b>CONSOLIDATED RENTAL CAR FACILITY SCL EASEMENT</b>	DATE 09/21/2012
	<b>SITE EXHIBIT</b>	SHEET NO. 01 OF 01





**BUS MAINTENANCE FACILITY SITE  
UTILITY IMPROVEMENT EASEMENT**

A STRIP OF LAND 10 FEET IN WIDTH SITUATED IN THE NORTHWEST QUARTER OF THE NORTHEAST QUARTER OF SECTION 04, TOWNSHIP 22 NORTH, RANGE 04 EAST, W.M., COUNTY OF KING, STATE OF WASHINGTON, THE SIDELINES OF SAID STRIP BEING 5 FEET ON EACH SIDE OF THE FOLLOWING DESCRIBED CENTERLINE:

COMMENCING AT THE CENTER OF SECTION 04, TOWNSHIP 22 NORTH, RANGE 04 EAST, W.M., THENCE SOUTH 89°52'18" EAST, ALONG THE SOUTH LINE OF THE NORTHEAST QUARTER OF SECTION 04, A DISTANCE OF 1349.02 FEET TO THE EASTERN LINE OF THE SOUTHWEST QUARTER OF THE NORTHEAST QUARTER OF SECTION 04, TOWNSHIP 22 NORTH, RANGE 04 EAST, W.M., THENCE NORTH 02°56'03" WEST, ALONG SAID EASTERN LINE OF THE SOUTHWEST QUARTER OF THE NORTHEAST QUARTER OF SECTION 04, A DISTANCE OF 1888.51 FEET, THENCE SOUTH 87°24'56" WEST A DISTANCE OF 65.43 FEET TO THE POINT OF BEGINNING.

THENCE SOUTH 87°24'56" WEST, A DISTANCE OF 27.87 FEET, TO A POINT HEREON REFERRED TO AS POINT "A";  
THENCE SOUTH 77°26'31" WEST, A DISTANCE OF 22.25 FEET;  
THENCE NORTH 85°32'48" WEST, A DISTANCE OF 51.13 FEET, TO A POINT HEREON REFERRED TO AS POINT "B";  
THENCE NORTH 69°16'00" WEST, A DISTANCE OF 26.71 FEET;  
THENCE NORTH 49°31'24" WEST, A DISTANCE OF 32.04 FEET;  
THENCE NORTH 35°34'50" WEST, A DISTANCE OF 28.00 FEET;  
THENCE NORTH 28°11'06" WEST, A DISTANCE OF 138.86 FEET, TO A POINT HEREON REFERRED TO AS POINT "C";  
THENCE NORTH 41°29'09" WEST, A DISTANCE OF 46.27 FEET, TO A POINT HEREON REFERRED TO AS POINT "D";  
THENCE NORTH 76°06'37" WEST, A DISTANCE OF 42.17 FEET;  
THENCE NORTH 86°37'07" WEST, A DISTANCE OF 32.04 FEET;  
THENCE SOUTH 88°44'30" WEST, A DISTANCE OF 89.52 FEET;  
THENCE NORTH 87°35'37" WEST, A DISTANCE OF 54.70 FEET, TO A POINT HEREON REFERRED TO AS POINT "E".  
THENCE SOUTH 89°46'39" WEST, A DISTANCE OF 48.78 FEET, TO A POINT HEREON REFERRED TO AS POINT "F".  
THENCE SOUTH 89°46'39" WEST, A DISTANCE OF 110.35 FEET;  
THENCE NORTH 88°39'54" WEST, A DISTANCE OF 43.58 FEET, TO A POINT HEREON REFERRED TO AS POINT "G";  
THENCE NORTH 88°31'33" WEST, A DISTANCE OF 23.00 FEET, TO A POINT HEREON REFERRED TO AS POINT "H";  
THENCE NORTH 88°58'05" WEST, A DISTANCE OF 35.93 FEET, TO A POINT HEREON REFERRED TO AS POINT "I";

THENCE NORTH 89°20'39" WEST, A DISTANCE OF 119.67 FEET, TO A POINT HEREON REFERRED TO AS POINT "J";  
THENCE NORTH 86°48'16" WEST, A DISTANCE OF 33.01 FEET;  
THENCE NORTH 73°51'41" WEST, A DISTANCE OF 24.87 FEET, TO A POINT HEREON REFERRED TO AS POINT "K";  
THENCE SOUTH 55°47'22" WEST, A DISTANCE OF 51.85 FEET;  
THENCE SOUTH 26°19'58" WEST, A DISTANCE OF 22.50 FEET;  
THENCE SOUTH 25°22'14" EAST, A DISTANCE OF 9.07 FEET;  
THENCE SOUTH 83°25'40" EAST, A DISTANCE OF 22.19 FEET;  
THENCE NORTH 25°26'38" EAST, A DISTANCE OF 4.96 FEET, TO A POINT HEREON REFERRED TO AS POINT "L", AND THE TERMINUS OF SAID DESCRIBED CENTERLINE.

THE SIDELINES OF SAID STRIP TO BE LENGTHENED OR SHORTENED TO INTERSECT AT ALL ANGLE POINTS AND TO TERMINATE AT SAID TERMINUS OF DESCRIBED CENTERLINES.

TOGETHER WITH:

THE FOLLOWING STRIPS OF LAND 10 FEET IN WIDTH SITUATED IN THE NORTHWEST QUARTER OF THE NORTHEAST QUARTER OF SECTION 04, TOWNSHIP 22 NORTH, RANGE 04 EAST, W.M., COUNTY OF KING, STATE OF WASHINGTON, THE SIDELINES OF SAID STRIP BEING 5 FEET ON EACH SIDE OF THE FOLLOWING DESCRIBED CENTERLINES:

BEGINNING AT AFORESAID POINT "A", THENCE NORTH 53°30'12" WEST, A DISTANCE OF 39.13 FEET TO THE TERMINUS OF SAID DESCRIBED CENTERLINE.

BEGINNING AT AFORESAID POINT "B", THENCE NORTH 20°10'06" EAST, A DISTANCE OF 24.67 FEET.

THENCE NORTH 88°44'04" EAST, A DISTANCE OF 15.80 FEET TO THE TERMINUS OF SAID DESCRIBED CENTERLINE.

BEGINNING AT AFORESAID POINT "C", THENCE NORTH 08°26'21" EAST, A DISTANCE OF 14.10 FEET;

THENCE NORTH 02°58'52" WEST, A DISTANCE OF 15.82 FEET TO THE TERMINUS OF SAID DESCRIBED CENTERLINE.

BEGINNING AT AFORESAID POINT "D", THENCE NORTH 48°48'16" EAST, A DISTANCE OF 5.54 FEET;

THENCE SOUTH 81°44'57" EAST, A DISTANCE OF 14.69 FEET TO THE TERMINUS OF SAID DESCRIBED CENTERLINE.

BEGINNING AT AFORESAID POINT "E", THENCE NORTH 33°27'37" WEST, A DISTANCE OF 28.61 FEET TO THE TERMINUS OF SAID DESCRIBED CENTERLINE.

BEGINNING AT AFORESAID POINT "F", THENCE NORTH 33°21'57" EAST, A DISTANCE OF 29.17 FEET TO THE TERMINUS OF SAID DESCRIBED CENTERLINE.

BEGINNING AT AFORESAID POINT "G", THENCE NORTH 45°54'51" WEST, A DISTANCE OF 30.24 FEET TO THE TERMINUS OF SAID DESCRIBED CENTERLINE.

BEGINNING AT AFORESAID POINT "H", THENCE SOUTH 00°00'00" EAST, A DISTANCE OF 51.39 FEET TO A POINT HEREON AFTER REFERRED TO AS POINT "M" AND THE TERMINUS OF SAID DESCRIBED CENTERLINE.

BEGINNING AT AFORESAID POINT "I", THENCE NORTH 44°30'50" EAST, A DISTANCE OF 28.88 FEET TO THE TERMINUS OF SAID DESCRIBED CENTERLINE.

BEGINNING AT AFORESAID POINT "J", THENCE NORTH 37°44'23" WEST, A DISTANCE OF 23.66 FEET TO THE TERMINUS OF SAID DESCRIBED CENTERLINE.

BEGINNING AT AFORESAID POINT "K", THENCE NORTH 68°45'10" EAST, A DISTANCE OF 27.27 FEET TO THE TERMINUS OF SAID DESCRIBED CENTERLINE.

THE SIDELINES OF SAID STRIPS TO BE LENGTHENED OR SHORTENED TO INTERSECT AT ALL ANGLE POINTS, AT THE WESTERLY AND EASTERLY MARGINS EXTENDED OF THOSE PORTIONS OF LAND TO BE DESCRIBED IN SUCCESSION BELOW, AND TO TERMINATE AT SAID TERMINUS OF DESCRIBED CENTERLINES.

TOGETHER WITH:

THE FOLLOWING DESCRIBED PORTIONS OF LAND SITUATED IN THE NORTHWEST QUARTER OF THE NORTHEAST QUARTER OF SECTION 04, TOWNSHIP 22 NORTH, RANGE 04 EAST, W.M., COUNTY OF KING, STATE OF WASHINGTON:

COMMENCING AT AFORESAID POINT "A"; THENCE NORTH 53°30'12" WEST, A DISTANCE OF 39.13 FEET TO THE POINT OF BEGINNING;

THENCE SOUTH 02°05'07" EAST, A DISTANCE OF 7.31 FEET;

THENCE SOUTH 87°31'50" EAST, A DISTANCE OF 16.79 FEET;

THENCE NORTH 03°18'26" WEST, A DISTANCE OF 14.61 FEET;

THENCE NORTH 87°28'31" EAST, A DISTANCE OF 17.10 FEET;

THENCE SOUTH 02°05'07" EAST, A DISTANCE OF 7.31 FEET TO THE POINT OF BEGINNING.

COMMENCING AT AFORESAID POINT "C", THENCE NORTH 08°26'21" EAST, A DISTANCE OF 14.10;

THENCE NORTH 02°58'52" WEST, A DISTANCE OF 15.82 FEET TO THE POINT OF BEGINNING.

THENCE SOUTH 38°27'36" WEST, A DISTANCE OF 7.31 FEET;

THENCE NORTH 51°02'55" WEST, A DISTANCE OF 16.97 FEET;

THENCE NORTH 38°27'23" EAST, A DISTANCE OF 14.62 FEET;  
THENCE SOUTH 51°01'09" EAST, A DISTANCE OF 16.97 FEET;  
THENCE SOUTH 38°27'36" WEST, A DISTANCE OF 7.31 FEET TO THE POINT OF BEGINNING.

COMMENCING AT AFORESAID POINT "E", THENCE NORTH 33°27'37" WEST, A DISTANCE OF 28.61 FEET TO THE POINT OF BEGINNING;  
THENCE SOUTH 01°18'06" WEST, A DISTANCE OF 7.28 FEET;  
THENCE NORTH 89°04'51" WEST, A DISTANCE OF 16.83 FEET;  
THENCE NORTH 00°17'55" EAST, A DISTANCE OF 14.63 FEET;  
THENCE SOUTH 88°50'45" EAST, A DISTANCE OF 17.09 FEET;  
THENCE SOUTH 01°18'06" WEST, A DISTANCE OF 7.28 FEET TO THE POINT OF BEGINNING.

COMMENCING AT AFORESAID POINT "G", THENCE NORTH 45°54'51" WEST, A DISTANCE OF 30.24 FEET TO THE POINT OF BEGINNING;  
THENCE SOUTH 02°47'16" WEST, A DISTANCE OF 7.28 FEET;  
THENCE NORTH 87°23'17" WEST, A DISTANCE OF 17.01 FEET;  
THENCE NORTH 03°06'15" EAST, A DISTANCE OF 14.59 FEET;  
THENCE SOUTH 87°15'47" EAST, A DISTANCE OF 16.93 FEET;  
THENCE SOUTH 02°47'16" WEST, A DISTANCE OF 7.28 FEET TO THE POINT OF BEGINNING.

COMMENCING AT AFORESAID POINT "J", THENCE NORTH 37°44'23" WEST, A DISTANCE OF 23.66 FEET TO THE POINT OF BEGINNING;  
THENCE SOUTH 00°39'42" EAST, A DISTANCE OF 7.30 FEET;  
THENCE SOUTH 89°48'39" WEST, A DISTANCE OF 17.01 FEET;  
THENCE NORTH 00°11'16" WEST, A DISTANCE OF 14.57 FEET;  
THENCE NORTH 89°42'08" EAST, A DISTANCE OF 16.89 FEET;  
THENCE SOUTH 00°39'42" EAST, A DISTANCE OF 7.30 FEET TO THE POINT OF BEGINNING.

BEGINNING AT AFORESAID POINT "M", THENCE SOUTH 90°00'00" EAST, A DISTANCE OF 11.07 FEET;  
THENCE SOUTH 00°00'00" EAST, A DISTANCE OF 12.15 FEET;  
THENCE NORTH 90°00'00" WEST, A DISTANCE OF 41.96 FEET;  
THENCE NORTH 00°00'00" EAST, A DISTANCE OF 12.15 FEET;  
THENCE NORTH 90°00'00" EAST, A DISTANCE OF 30.88 FEET TO SAID POINT "M" AND THE POINT OF BEGINNING.

ALL DESCRIBED PORTIONS CONTAINING 15,953 SQUARE FEET OR .37 ACRES, MORE OR LESS.

PORTION OF THE  
SECTION 04 TWN. 22 N., RNG. 04 E., W.M.  
KING COUNTY, WASHINGTON

LINE TABLE		
LINE	LENGTH	BEARING
L1	1349.02	S89°52'18"E
L2	1888.51	N02°56'03"W
L3	65.43	S87°24'56"W
L4	27.87	S87°24'56"W
L5	22.25	S77°26'31"W
L6	51.13	N85°32'48"W
L7	26.71	N69°16'00"W
L8	32.04	N49°31'24"W
L9	28.00	N35°34'50"W
L29	39.13	N53°30'12"W
L30	24.67	N20°10'06"E
L31	15.80	N88°44'04"E
L43	7.31	S02°05'07"E
L44	16.79	S87°31'50"W
L45	14.61	N03°18'26"W
L46	17.10	N87°28'31"E
L47	7.31	S02°05'07"E

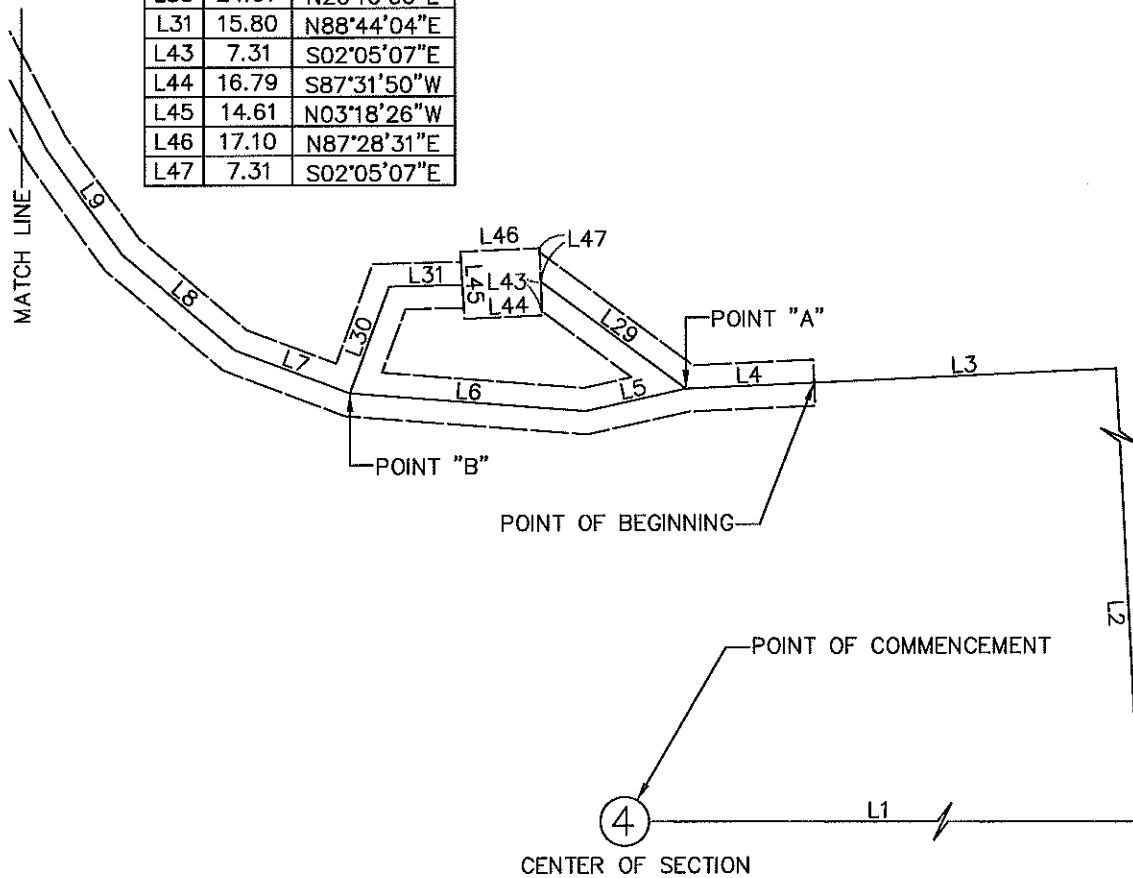

**BUS MAINTENANCE FACILITY  
UTILITY IMPROVEMENT  
EASEMENT**

EASEMENT EXHIBIT

DATE  
Sept. 28, 2012

SHEET NO.  
01 OF 05

PORTION OF THE  
SECTION 04 TWN. 22 N., RNG. 04 E., W.M.  
KING COUNTY, WASHINGTON

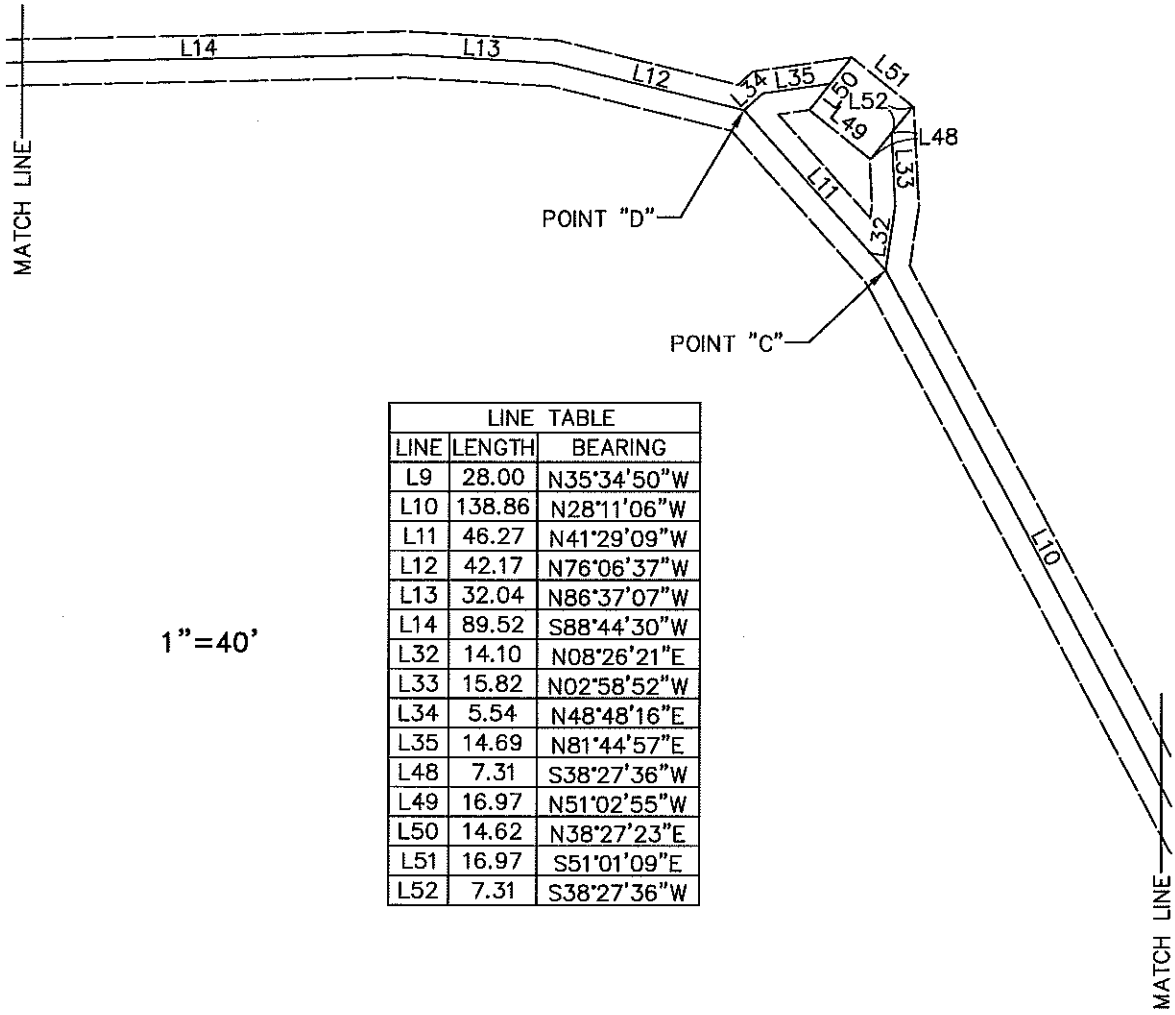

LINE TABLE		
LINE	LENGTH	BEARING
L9	28.00	N35°34'50"W
L10	138.86	N28°11'06"W
L11	46.27	N41°29'09"W
L12	42.17	N76°06'37"W
L13	32.04	N86°37'07"W
L14	89.52	S88°44'30"W
L32	14.10	N08°26'21"E
L33	15.82	N02°58'52"W
L34	5.54	N48°48'16"E
L35	14.69	N81°44'57"E
L48	7.31	S38°27'36"W
L49	16.97	N51°02'55"W
L50	14.62	N38°27'23"E
L51	16.97	S51°01'09"E
L52	7.31	S38°27'36"W



**BUS MAINTENANCE FACILITY  
UTILITY IMPROVEMENT  
EASEMENT**

**EASEMENT EXHIBIT**

DATE	Sept. 28, 2012
SHEET NO.	02 OF 05

PORTION OF THE  
SECTION 04 TWN. 22 N., RNG. 04 E., W.M.  
KING COUNTY, WASHINGTON

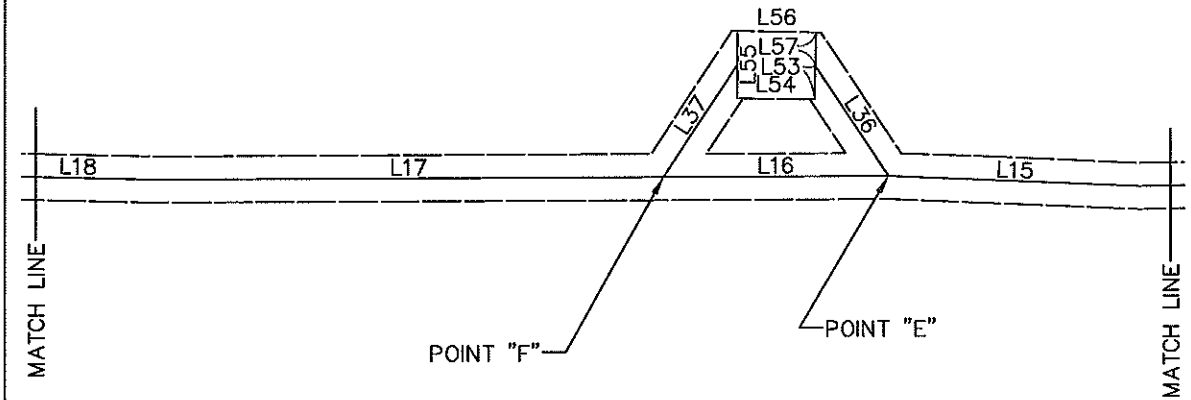

LINE TABLE		
LINE	LENGTH	BEARING
L15	54.70	N87°35'37"W
L16	48.78	S89°46'39"W
L17	110.35	S89°46'39"W
L18	43.58	N88°39'54"W
L36	28.61	N33°27'37"W
L37	29.17	N33°21'57"E
L53	7.28	S01°18'06"W
L54	16.83	N89°04'51"W
L55	14.63	N00°17'55"E
L56	17.09	S88°50'45"E
L57	7.28	S01°18'06"W

1"=40'

	<b>BUS MAINTENANCE FACILITY UTILITY IMPROVEMENT EASEMENT</b>	DATE Sept. 28, 2012
	<b>EASEMENT EXHIBIT</b>	SHEET NO. 03 OF 05

PORTION OF THE  
SECTION 04 TWN. 22 N., RNG. 04 E., W.M.  
KING COUNTY, WASHINGTON

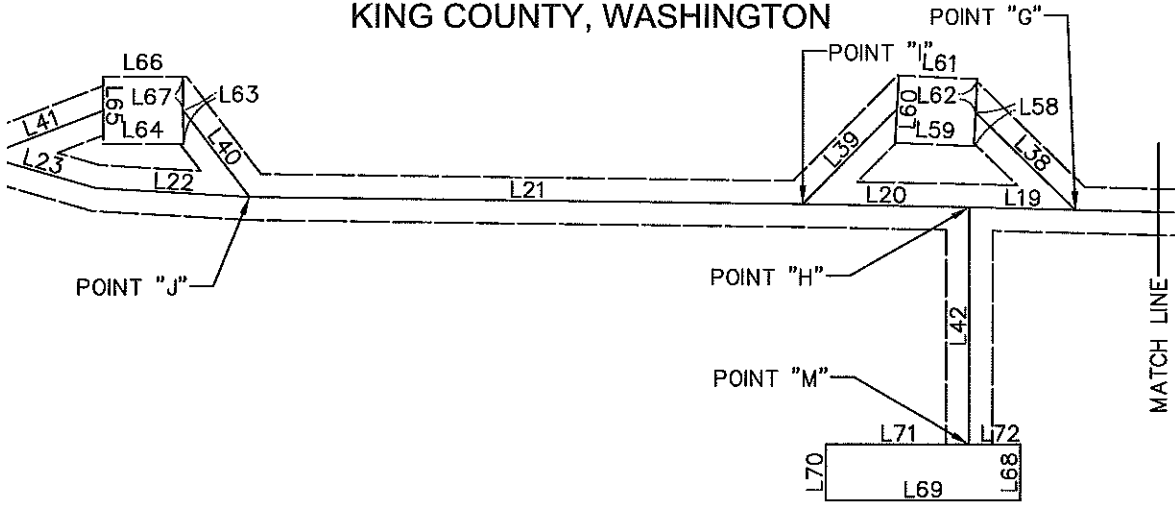

LINE TABLE		
LINE	LENGTH	BEARING
L19	23.00	N88°31'33"W
L20	35.93	N88°58'05"W
L21	119.67	N89°20'39"W
L22	33.01	N86°48'16"W
L23	24.87	N73°51'41"W
L38	30.24	N45°54'51"W
L39	28.88	N44°30'50"E
L40	23.66	N37°44'23"W
L41	27.27	S68°45'10"W
L42	51.39	S00°00'00"E
L58	7.28	S02°47'16"W
L59	17.01	N87°23'17"W
L60	14.59	N03°06'15"E
L61	16.93	S87°15'47"E
L62	7.28	S02°47'16"W
L63	7.30	S00°39'42"E
L64	17.01	S89°48'39"W
L65	14.57	N00°11'16"W
L66	16.89	N89°42'08"E
L67	7.30	S00°39'42"E

1" = 40'



**BUS MAINTENANCE FACILITY  
UTILITY IMPROVEMENT  
EASEMENT**

**EASEMENT EXHIBIT**

DATE	Sept. 28, 2012
SHEET NO.	04 OF 05



PORTION OF THE  
SECTION 04 TWN. 22 N., RNG. 04 E., W.M.  
KING COUNTY, WASHINGTON

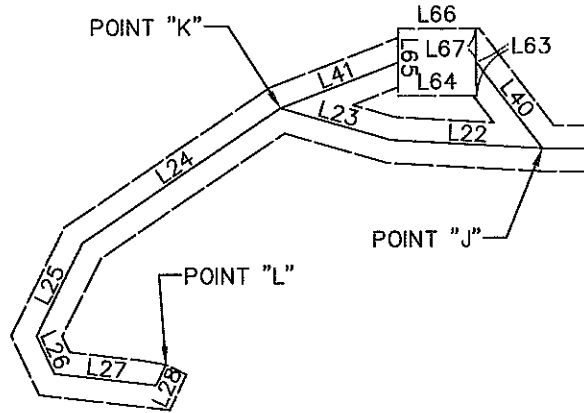

LINE TABLE					
LINE	LENGTH	BEARING	LINE	LENGTH	BEARING
L22	33.01	N86°48'16"W	L63	7.30	S00°39'42"E
L23	24.87	N73°51'41"W	L64	17.01	S89°48'39"W
L24	51.85	S55°47'22"W	L65	14.57	N00°11'16"W
L25	22.50	S26°19'58"W	L66	16.89	N89°42'08"E
L26	9.07	S25°22'14"E	L67	7.30	S00°39'42"E
L27	22.19	S83°25'40"E			
L28	4.96	N25°26'38"E			
L29	39.13	N53°30'12"W			
L30	24.67	N20°10'06"E			
L31	15.80	N88°44'04"E			
L32	14.10	N08°26'21"E			
L33	15.82	N02°58'52"W			
L34	5.54	N48°48'16"E			
L35	14.69	N81°44'57"E			
L36	28.61	N33°27'37"W			
L37	29.17	N33°21'57"E			
L38	30.24	N45°54'51"W			
L39	28.88	N44°30'50"E			
L40	23.66	N37°44'23"W			
L41	27.27	S68°45'10"W			

1" = 40'



**BUS MAINTENANCE FACILITY  
UTILITY IMPROVEMENT  
EASEMENT**

**EASEMENT EXHIBIT**

DATE  
Sept. 28, 2012

SHEET NO.

05 OF 05

